

## RFQ SUBMISSION REQUIREMENTS

Submit the following to be received by 5 p.m., January 25, 2010:

- 1) A current resume (limit three pages)
  - a. Contact information
  - b. Web site
  - c. Relevant exhibits, commissions, or installations
  - d. Relevant teaching, professional experiences or publications.
- 2) Artist Statement – introduce us to you and your work. (limit one page)
- 3) Three references, preferably owners or commissioning agents.
- 4) A CD showing projects of similar scale or type for reference
  - a. limit 12 photographs
  - b. high quality jpg images, 1000 dpi format at the largest dimension
  - c. Some detail shots are encouraged.
  - d. File naming format: image number – artist – title (i.e. 1 - John Artist – Glass Panel).
- 5) An image list corresponding to the images on the CD including the following:
  - a. File Name (i.e. 1 - John Artist – Glass Panel)
  - b. Title of work, materials, year
  - c. Location and owner or commissioning agent
  - d. Original commission or sale of piece.
- 6) A narrative description of how you would approach this project. Feel free to make references to any of the submitted images of past work. Any sketches or other materials you think necessary to illustrate your thinking are optional and not required for the RFQ phase.

### MAIL SUBMISSIONS TO:

**Glass Public Art Project**  
**City of Kettering**  
**CitySites** Public Art  
**Rosewood Arts Centre**  
**2655 Olson Drive**  
**Kettering, OH 45420**

### FOR MORE INFORMATION CONTACT

Connie Campbell  
Cultural Arts Superintendent  
Rosewood Arts Centre  
2655 Olson Drive  
Kettering, OH 45420  
Phone: 937.296.0294  
Fax: 937.296.3289  
email: [connie.campbell@ketteringoh.org](mailto:connie.campbell@ketteringoh.org)

Visit our website for prospectus: [www.ketteringoh.org](http://www.ketteringoh.org)  
and click on: **Glass Public Art Project**



**CITY OF KETTERING**

PARKS, RECREATION AND CULTURAL ARTS DEPARTMENT

# GLASS PUBLIC ART PROJECT

The City of Kettering, Ohio invites artists from the states of Ohio, Indiana, Michigan, Kentucky, Pennsylvania and West Virginia to submit qualifications for a public art glass panel or suspended glass sculpture to be installed in the Kettering Government Center building. The glass panel/sculpture design will be part of a major \$3.0 million renovation plan for the Kettering Government Center. This is a two-phase selection process (1–qualifications, 2–proposal) with a final commission fee of \$40,000.



Public Art in Kettering

## ABOUT KETTERING

The City of Kettering, Ohio is located five miles south of the City of Dayton and 40 miles north of Cincinnati. With a resident population of 62,000, the City of Kettering features award-winning urban parks and green spaces, recreational and leisure facilities and cultural arts programs. The Kettering Government Center is a "brutalist style" contemporary triangular structure built in 1969 utilizing board formed concrete and large glass walls.



The Kettering public art program, CitySites, was established in 1999 by the City of Kettering Parks, Recreation and Cultural Arts Department to enhance neighborhoods and the urban environment through the installation

and maintenance of public works of art. The program is funded through one percent of the City's previous year capital improvement expenditures.

## ABOUT THE PROJECT LOCATION



The window is located above the main entrance to the building. During construction the City will be replacing the framing

and the glass with new insulated glass to serve as the exterior protection of the art glass. The original shape and pattern of the current glass frames will be maintained as a reference to the building's past. This window has a strong western exposure and the new exterior glass will have some form of tinting, shading or frit to diminish the overbearing direct western light. The primary interior view of the window is from the upper level City Council

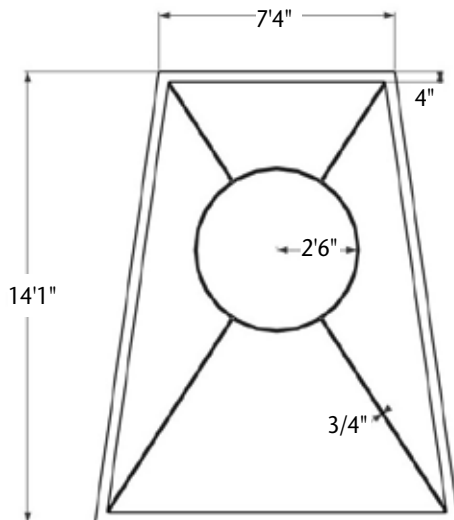

Chambers and looks out toward the sky and the upper part of three flagpoles that provide a visual identity to the space and connect the indoors with the outdoors. The dramatic location is one of the most visual in the facility with approximately 150 square feet of glass.

## GENERAL PROJECT REQUIREMENTS

The new glass panel/sculpture must allow for some view of the flags from within the council chambers. While some use of color is acceptable it is expected that the glass will be primarily some combination of clear, frosted, obscured, patterned etc. The art glass may be either glass panels installed within the new frames

provided by the renovation or free floating glass objects in front of the window that compose a sculpture. The artist should consider the lighting affect that the art glass/sculpture will have on the sloped plaster ceilings and the overall council chambers. The commission of \$40,000 will include all materials, construction and installation of the public art glass panel.

## SELECTION PROCESS

### TWO-PHASE SELECTION PROCESS

- 1) Phase 1 - The initial artists' RFQ Submissions will be reviewed by the Kettering Art in Public Places Committee. One or more artists will be selected and commissioned to visit the site and submit concepts and detailed drawings of the proposed design.
- 2) Phase 2 - each selected artist will be commissioned for \$1,000 to cover expenses during the final proposal process. The Art in Public Places Committee will review the concept proposals for final selection of an artist. Upon

final selection, the City of Kettering will provide a contract to the artist for the fee of \$40,000 to be paid in three installments to cover all travel, hospitality, fabrication, outside contractual assistance and installation of the public art project. The artist will work with the architectural design firm, the construction contractor and the City of Kettering staff to meet the deadlines for installation. The artist will be present to assist and supervise the installation of the glass panels /sculpture after completion of fabrication.

## CALENDAR SCHEDULE

January 25, 2010, 5 p.m.	Deadline for Receipt of Qualifications
February 22, 2010	Notification to Artists
February – March	Site Visits
April 26, 2010	Artists Final Design Submission
May 14, 2010	Final Artist Selection Notification
October, 2010	Installation of Artwork